



**Wheelchair accessibility for
home or public buildings
over straight stairways**

**Folds up compactly when
not in use leaving access
to the stairs**

**Custom order for your
specific needs**

Savaria® Delta Inclined Platform Lift

ACCESS OVER STRAIGHT STAIRS



The Savaria Delta inclined platform lift provides wheelchair access over straight stairs as it travels along a modular guide rail system. When not in use, the unit folds compactly to the wall, leaving access to the stairs. The Delta lift is a popular choice for churches, schools and homes with minimal construction needed for installation.

Battery operated with charging stations located at the top and bottom of the stairs, the lift continues to function even through a power failure. Choose from four platform sizes, including ADA-compliant size, and select options such as a folding seat, automatic folding/unfolding or a public building package.

Savaria® Delta Inclined Platform Lift

ACCESS OVER STRAIGHT STAIRS



- Folds up compactly (18"/45.7 cm) from the wall when not in use allowing easy access to the stairs
- Durable construction and reliable components to stand up to day-to-day use even in commercial settings
- Easy installation, often without major construction requirements
- Configure for straight through access or 90° entry/exit with a variety of standard platform sizes available
- Battery operation with top and bottom landing charging stations
- Pendant control with constant pressure operation, keyed for security
- Safety features include edge and underpan obstruction sensors, overspeed safety brake, safety arms, platform ramps, emergency stop button, limit switches, manual operation (using handwheel), lockable master power switch
- Optional features: automatic folding/unfolding for platform and arms, public building package, folding seat

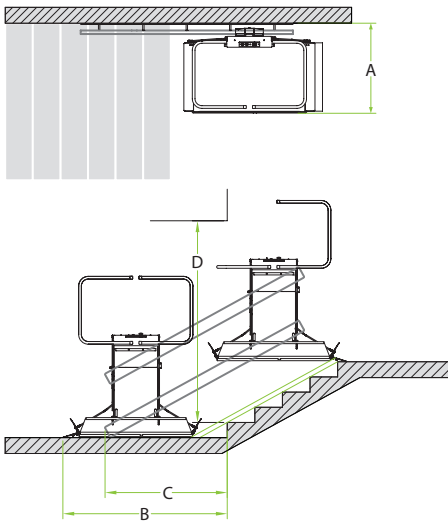

SPECIFICATIONS

Applications	Residential, commercial, indoor
Stair types	Straight, single flight with constant gradient
Capacity	550 lb (250 kg), optional 660 lb (300 kg) USA only
Travel distance	8" (20 cm) to 40' (12 m) residential 8" (20 cm) to 80' (24 m) commercial
Finish Color	Light gray (RAL 7035)
Nominal speed	20 ft/min (0.10 m/s)
Motor	0.66 hp (0.5 kW)
Power	24V DC (battery system); 120V AC for charger
Warranty	36 months parts, ask dealer for details

Outdoor applications are limited by your specific climate conditions, consult with your local dealer

CLEARANCES

Platform size	28.4" x 35.5" (720 x 900 mm)	27" x 36" (685 x 914 mm)	28.5" x 44" (724 x 1118 mm)	30.5" x 49.3" (775 x 1250 mm)
Unfolded width (A)	37.8" (959 mm)	36.4" (923 mm)	38" (966 mm)	40" (1017 mm)
Bottom landing (B)*	60.2"-54.4" (1530-1381 mm)	60.8"-54.9" (1544-1395 mm)	68.8"-62.9" (1747-1598 mm)	74"-68.1" (1880-1731 mm)
End of rail (C)*	44.9"-38.2" (1140-971 mm)	45.2"-38.5" (1147-978 mm)	49.2"-42.5" (1249-1080 mm)	51.8"-45.1" (1315-1146 mm)
Overhead (D)*	80.8"-94.6" (2053-2402 mm)	81.1"-95" (2059-2413 mm)	84.8"-101.6" (2153-2580 mm)	87.2"-106" (2215-2692 mm)

Values given for straight through entrance, see planning guide for 90° entrance which requires additional clearance. For post-mounted units add 3.5" to the unfolded platform width. *Clearances range based on stair angle, values are stated 35° to 40°, see planning guide for complete details.

Authorized Savaria Dealer:



LIFT & COMPACTORS MEXICO, S.A. DE C.V.
 KM. 69.5-A CARR. FED. MEXICO - CUERNAVACA
 COL. STA. MA. AHUACATITLAN, CUERNAVACA,
 MORELOS, MEXICO C.P. 62100
 TEL.- (777) 317-5084, 317-8173,
 01800-830-0999
WWW.LCMEX.COM
 Email.- VENTAS@LCMEX.COM



www.savaria.com

2 Walker Drive, Brampton, ON L6T 5E1 Canada
 tel: 800.661.5112 fax: 905.791.2222